



Horn Loudspeakers

Plastic Horns

P-HP-30(T)

Bracket and all outside nuts and bolts in stainless steel.

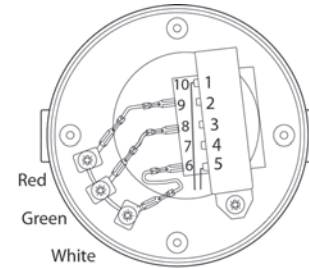
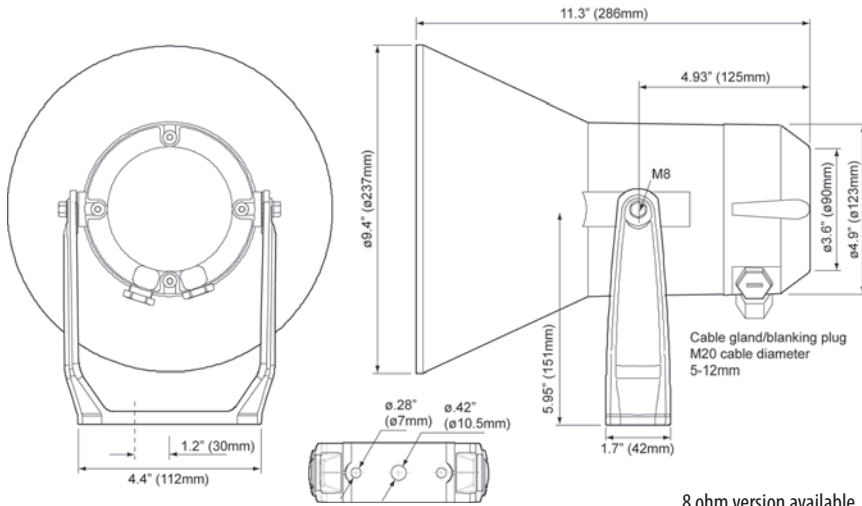

70/100 volt combined transformer:

Primary connections:

White : Green 70 V

White : Red 100 V

Secondary nominal tapings:

1:5 30.0 W 1:2 7.5 W

1:4 20.0 W 2:4 3.5 W

1:3 15.0 W 2:3 2.0 W

8 ohm version available

Specifications

Material / Color	Polyamide / RAL 7035
Mounting	Bracket
Termination	Internal screw connections
Weight w/transformer	4.7 lbs (2.1 kg)
IP-rating (UL Equivalent)	67
Max. / min. amb. temp	302°F / -58°F (150°C / -50°C)
Rated / max. power	30 W / 40 W
SPL 1W/1m	110 dB
SPL rated power	124 dB
Effective freq. range	310 – 8000 Hz
Dispersion (-6dB) 1kHz / 4kHz	115° / 30°
Options	Impedance, color, label

Sound pressure levels 1W/1m sine wave

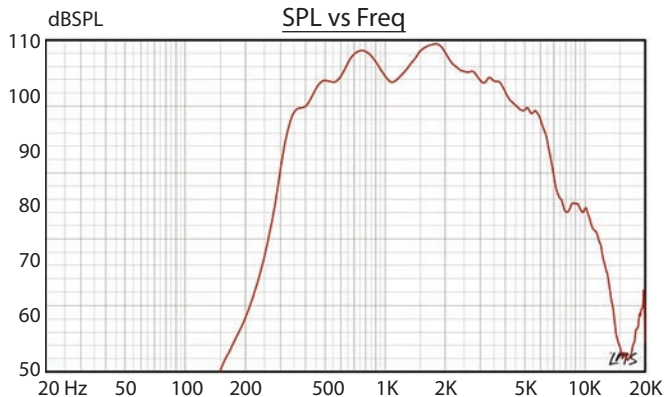

Installation, Operation and Maintenance Procedures

- Unscrew lid (4 screws). Lead cable through cable gland and connect to screw terminal (100 V or 70 V)
- Tapp transformer to wanted power. Tighten cable gland to ensure IP-Grade
- Fasten lid with a torque of 2 - 3 Nm.
- Fasten bracket with 1- 3 screws.
- To change the position of the loudspeaker adjust the bracket (by loosening / tightening the screws) as required.
- For optimum performance, always use the correct voltage / power and operate within the frequency limits as stated.
- **Do not** open loudspeaker when energized.
- This loudspeaker is supplied with a 2 year warranty against defective materials and workmanship.



The Manufacturer reserves the right to alter specifications without notice.

